

**Model A-C2**  
**PRINTER/SCANNER CONTROLLERS**  
**(Machine Code: B361, B362)**  
**SERVICE MANUAL**

January 19th, 2001  
Subject to change

**Trademarks**

Microsoft<sup>®</sup>, Windows<sup>®</sup>, and MS-DOS<sup>®</sup> are registered trademarks of Microsoft Corporation in the United States and /or other countries.

PostScript<sup>®</sup> is a registered trademark of Adobe Systems, Incorporated.

PCL<sup>®</sup> is a registered trademark of Hewlett-Packard Company.

Ethernet<sup>®</sup> is a registered trademark of Xerox Corporation.

Other product names used herein are for identification purposes only and may be trademarks of their respective companies. We disclaim any and all rights involved with those marks.

# TABLE OF CONTENTS

<b>1</b>	<b>INSTALLATION .....</b>	<b>1-1</b>
1.1	INSTALLATION REQUIREMENTS .....	1-1
1.2	PRINTER INSTALLATION .....	1-1
1.3	POSTSCRIPT UNIT (G577) .....	1-7
1.4	MEMORY (G578/G579) .....	1-8
1.5	NIB (G574) .....	1-9
1.6	IEEE1394 INTERFACE (G590) .....	1-10
1.7	CHECKING THE CONNECTIONS .....	1-11
<b>2</b>	<b>TROUBLESHOOTING .....</b>	<b>2-1</b>
2.1	CONTROLLER ERRORS .....	2-1
2.2	LEDS AND TEST POINTS .....	2-1
<b>3</b>	<b>SERVICE TABLES.....</b>	<b>3-1</b>
3.1	SERVICE PROGRAM MODE.....	3-1
3.1.1	ENABLING AND DISABLING SERVICE PROGRAM MODE .....	3-1
3.2	PRINTER SERVICE MODE .....	3-2
3.2.1	SERVICE MODE TABLE .....	3-2
3.2.2	SP MODES RELATED TO PRINTER CONTROLLER .....	3-2
3.3	SCANNER SERVICE MODE.....	3-3
3.3.1	SCANNER PROGRAM MODE TABLE.....	3-3
3.4	FIRMWARE UPDATE PROCEDURE.....	3-11
3.5	POWER-ON SELF TEST .....	3-11
3.6	SELF DIAGNOSTIC TEST .....	3-11
3.7	USER PROGRAM MODE .....	3-12
3.7.1	PRINTER USER PROGRAM MODE.....	3-12
3.7.2	SCANNER USER PROGRAM MODE .....	3-13
<b>4</b>	<b>DETAILED SECTION DESCRIPTIONS .....</b>	<b>4-1</b>
4.1	OVERVIEW .....	4-1
4.2	CONTROLLER FUNCTIONS .....	4-2
4.2.1	SAMPLE PRINT .....	4-2
4.2.2	LOCKED PRINT .....	4-2
4.2.3	PAPER SOURCE SELECTION.....	4-3
4.2.4	AUTO CONTINUE .....	4-4
4.2.5	PAPER OUTPUT TRAY .....	4-5
4.2.6	DUPLEX PRINTING .....	4-5
4.2.7	STAPLING.....	4-6
4.2.8	PUNCHING .....	4-6
4.3	SCANNER FUNCTIONS.....	4-7
4.3.1	IMAGE PROCESSING FOR SCANNER MODE .....	4-7
4.4	NIB .....	4-8
4.4.1	BLOCK DIAGRAM.....	4-8
4.4.2	LED INDICATORS.....	4-8
4.5	IEEE1394 INTERFACE .....	4-9

4.5.1 SPECIFICATIONS.....	4-9
4.5.2 IEEE1394 .....	4-9
4.5.3 BLOCK DIAGRAM.....	4-10
4.5.4 PIN ASSIGNMENT .....	4-10
4.5.5 REMARKS ABOUT THIS INTERFACE KIT.....	4-11
4.5.6 TROUBLESHOOTING NOTES .....	4-11

<b>SPECIFICATIONS.....</b>	<b>SPEC-1</b>
1 GENERAL SPECIFICATIONS.....	SPEC-1
1.1 PRINTER.....	SPEC-1
1.2 SCANNER .....	SPEC-3
2 SOFTWARE ACCESSORIES .....	SPEC-4
2.1 PRINTER.....	SPEC-4
2.2 SCANNER .....	SPEC-5
3 MEACHINE CONFIGURATION.....	SPEC-6
3.1 SYSTEM COMPONENTS .....	SPEC-6

# 1. INSTALLATION

## 1.1 INSTALLATION REQUIREMENTS

Please refer to section 1 of the main unit service manual.

## 1.2 PRINTER INSTALLATION

### *Accessory Check*

Check the accessories in the box against the following list:

No.	Description	Q'ty	Note
1	Cable	1	
2	Paper Height Sensors	4	
3	Edge Clamp	1	
4	Cable Clamp	4	
5	Paper Height Sensor Feeler	2	
6	Paper Sensor	1	
7	Key Top - Printer	1	
8	Key Top - Scanner	1	Included only in the B362 (printer and scanner) model
9	Paper Limit Sensor Unit	1	
10	Tapping Screw - M3x8	2	To secure the paper limit sensor unit
11	Pan Head Screw - M3x8	1	To secure the paper sensor
12	Installation Procedure	1	
13	FCC Label	1	Included only in the USA models.

**Printer Controller Installation**

**⚠ CAUTION**  
**Unplug the main machine power cord before starting the following procedure.**

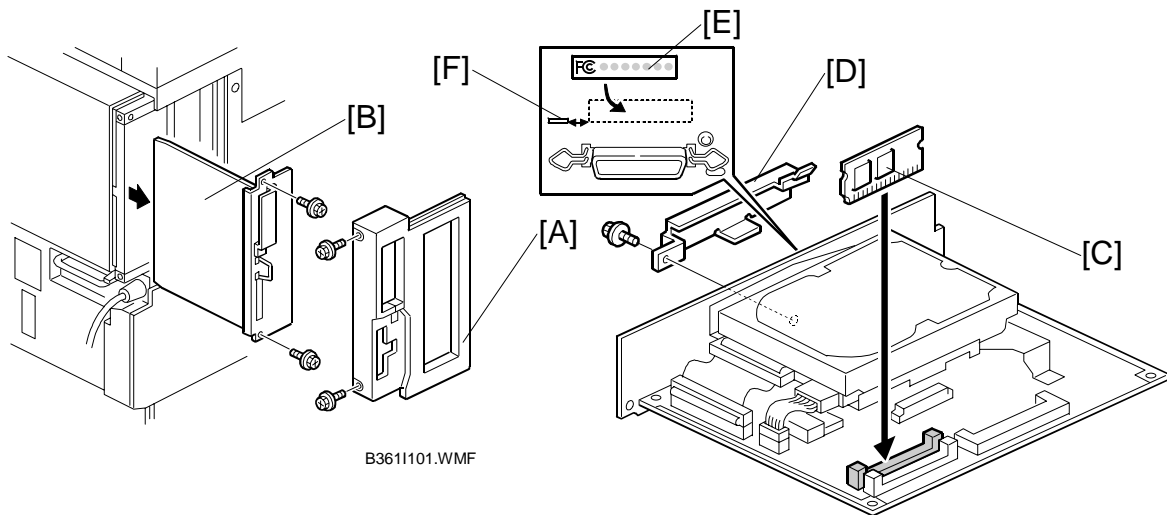

B3611101.WMF

B3611107.WMF

1. Remove the left rear cover [A] (2 screws) and slide out the controller board [B] (2 screws).
2. Install the printer ROM DIMM [C] on the controller board.
3. Remove the parallel interface cover [D].
4. **This step is required only in the USA models.**  
 Attach the FCC label [E] on the controller panel board aligned with the slot [F] so the label is hidden when the left rear cover is replaced.

**NOTE:** If the NIB (G574), Postscript kit (G577), memory board (G578/G579), or IEEE1394 Interface (G590) are to be installed, remove the HDD and install them before proceeding to the next step.

5. Put back the controller board and replace the left rear cover.

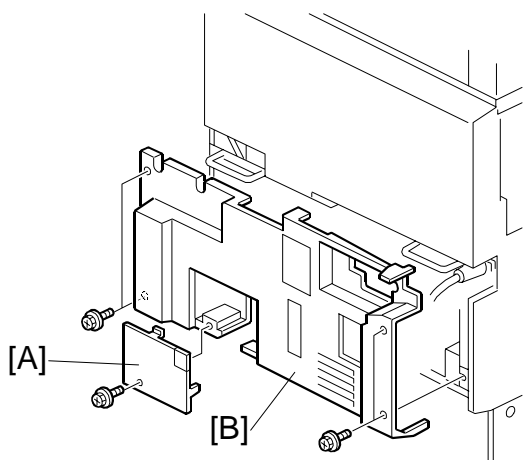
**Paper Height Sensor Installation**

B361112.WMF

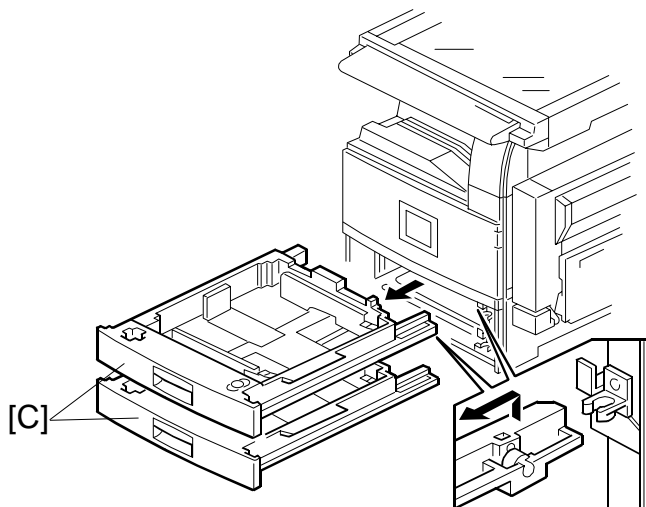

B261142.WMF

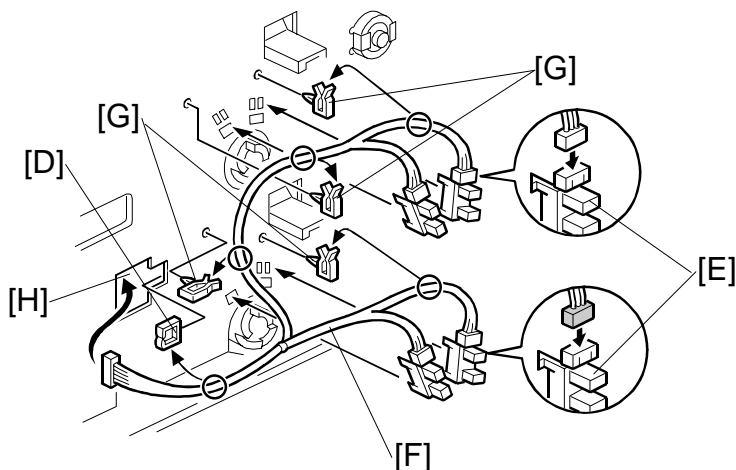

B361108.WMF

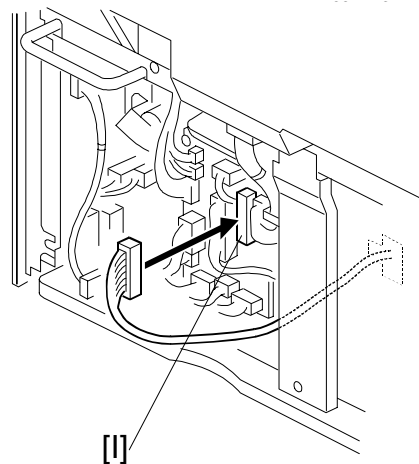

B361109.WMF

6. Remove the connector cover [A] and lower rear cover [B] (5 screws).
7. Pull out the two paper trays [C].
8. Install edge clamp [D] in the opening.
9. Connect the four paper height sensors [E] to the cable [F].
10. Install the four paper height sensors [E] as shown.
11. Install the four cable clamps [G], then clamp the cable as shown.
12. Lead the cable through the opening [H]. Secure the cable in place with the edge clamp attached in step 8.
13. Connect the cable to CN234 on the PCB [I].

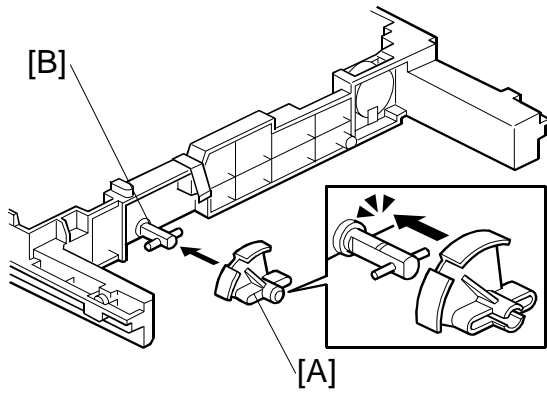

B3611114.WMF

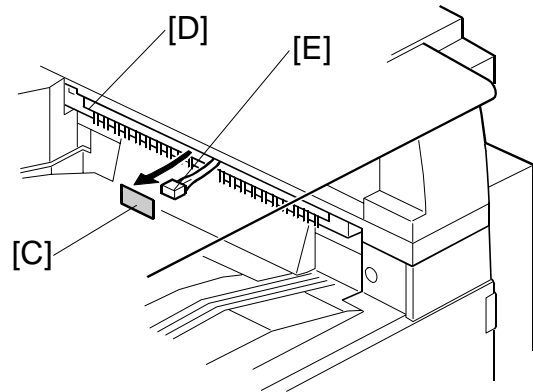

B3611115.WMF

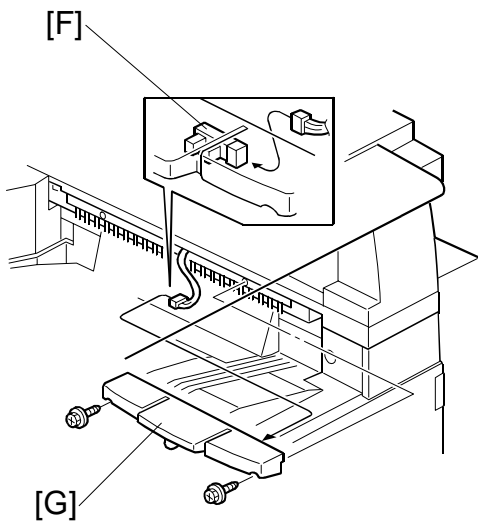

B3611116.WMF

14. Install the paper height sensor feeler [A] on the bottom plate shaft [B] of each paper tray.
15. Reassemble the machine.

***Paper Limit Sensor Installation***

**If the optional bridge unit has been installed, skip steps 16 and 17.**

16. Peel off the black tape [C] from the anti-static brush [D], then pull out the cable [E].
17. Connect the cable to the sensor [F], then install the paper limit sensor unit [G] (2 screws).

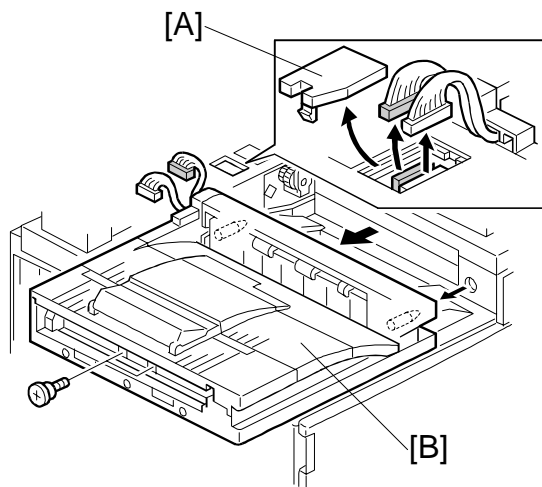

**Paper Sensor Installation**

B358I518.WMF

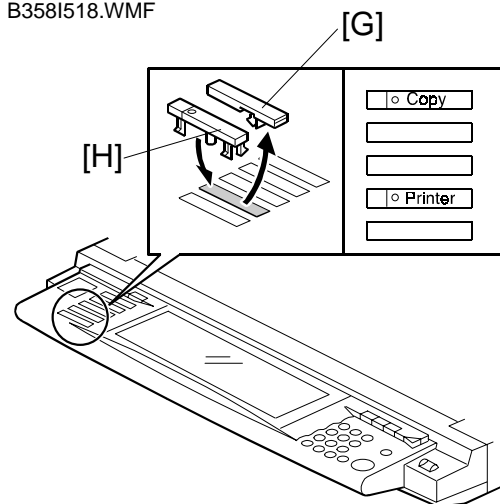

B361I110.WMF

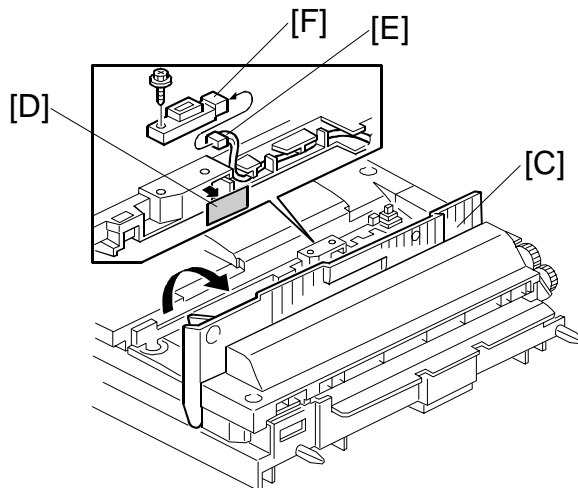

B358I517.WMF

**Perform steps 18 to 20 only if the optional bridge unit has been installed. If it has not been installed, go on to step 21.**

18. Remove the connector cover [A] and bridge unit [B] (2 screws, 2 connectors).
19. Open the right cover [C] of the bridge unit and peel off the black tape [D], then pull out the connector [E].
20. Install the paper sensor [F] (1 screw, 1 connector) and reinstall the bridge unit.

**Completion**

21. Remove the bottom cap [G] of the operation panel. Install the **Printer** key [H] on the operation panel as shown.

22. Do not connect the parallel cable at this point. Turn the machine on and check the setting of the following copier SP mode:
  - SP5-907: Plug & Play Name - select the correct one.
23. Print out the configuration page to check if the printer controller is installed properly.  
(Configuration page: User Tools/ Printer Settings/ List Test Print/ Config. Page)
24. If the parallel cable is going to be connected, first turn off the machine. After connecting the cable, turn the machine back on.

## 1.3 POSTSCRIPT UNIT (G577)

### ⚠ CAUTION

Unplug the main machine power cord before starting the following procedure.

**NOTE:** To install the Postscript option, the printer option (B361) must be installed first. Please refer to section 1.2 for details of the printer option installation procedure.

1. Remove the left rear cover [A] (2 screws).

2. Remove the controller board [B] (2 screws).

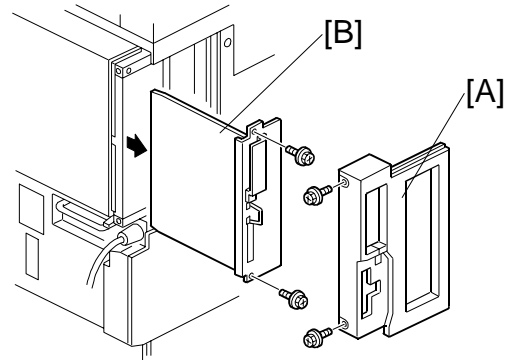

R3611101.WMF

3. Install the Postscript DIMM [C] onto the controller board [D].

4. Put back the controller board and replace the left rear cover.

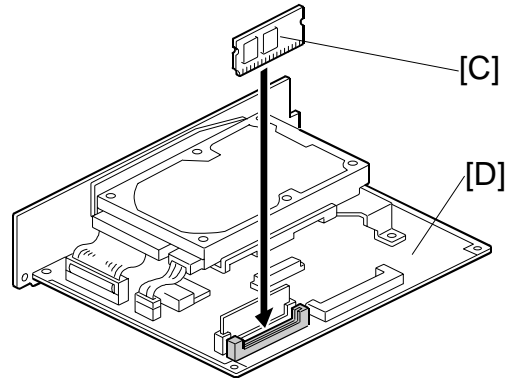

B3611104.WMF

## 1.4 MEMORY (G578/G579)

### **⚠ CAUTION**

**Unplug the main machine power cord before starting the following procedure.**

**NOTE:** To install the memory option, the printer option (B361) must be installed first. Please refer to section 1.2 for details of the printer option installation procedure.

1. Remove the left rear cover [A] (2 screws).
2. Remove the controller board [B] (2 screws).

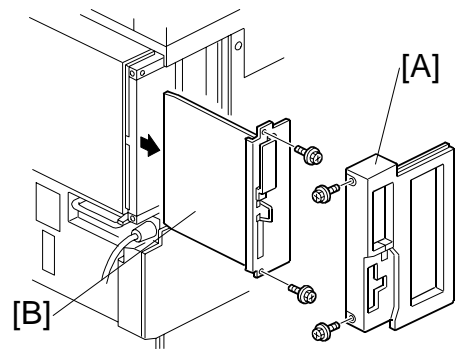

B3611101.WMF

3. Remove the HDD [C] (2 connectors, 3 screws).

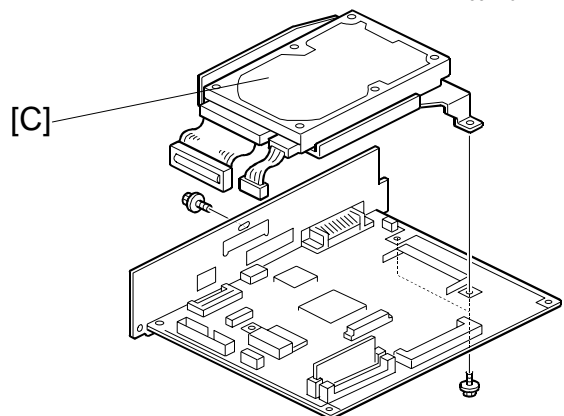

B3611102.WMF

4. Install the memory DIMM [D] onto the controller board [E].
5. Re-install the HDD and put back the controller board.
6. Replace the left rear cover.

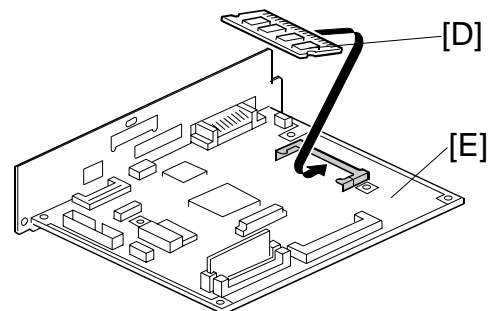

B3611117.WMF

## 1.5 NIB (G574)

### ⚠ CAUTION

**Unplug the main machine power cord before starting the following procedure.**

**NOTE:** To install the NIB option, the printer option (B361) must be installed first. Please refer to section 1.2 for details of the printer option installation procedure.

1. Remove the left rear cover [A] (2 screws).
2. Remove the controller board [B] (2 screws).

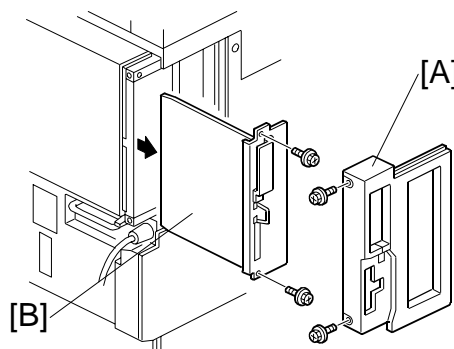

B3611101.WMF

3. Remove the HDD [C] (2 connectors, 3 screws).

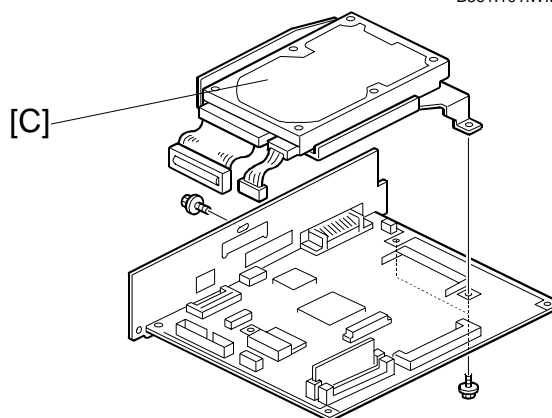

B3611102.WMF

4. Remove the NIB slot cover [D].
5. Attach the NIB [E] to the controller board [F] (2 screws).
6. Re-install the HDD and put back the controller board.
7. Replace the left rear cover.

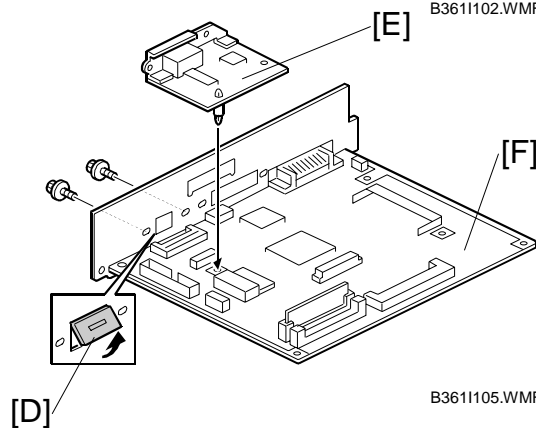

B3611105.WMF

## 1.6 IEEE1394 INTERFACE (G590)

### ⚠ CAUTION

**Unplug the main machine power cord before starting the following procedure.**

**NOTE:** To install the IEEE1394 option, the printer option (B361) must be installed first. Please refer to section 1.2 for details of the printer option installation procedure.

1. Remove the left rear cover [A] (2 screws).
2. Remove the controller board [B] (2 screws).

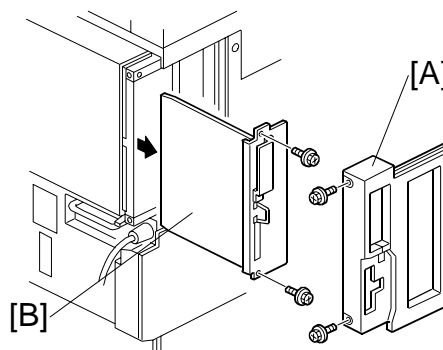

B3611101.WMF

3. Remove the HDD [C] (2 connectors, 3 screws).

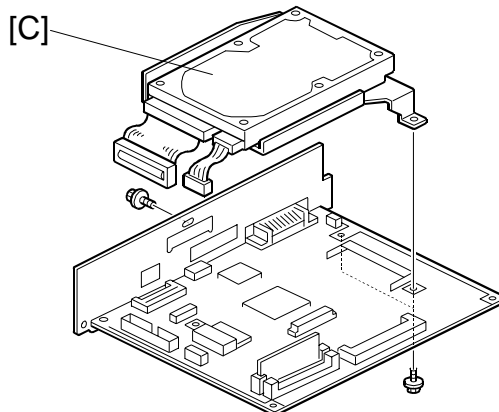

B3611102.WMF

4. Remove the IEEE1394 cover [D].
5. Attach the IEEE1394 board [E] to the controller board [F] (2 screws).
6. Re-install the HDD and put back the controller board.

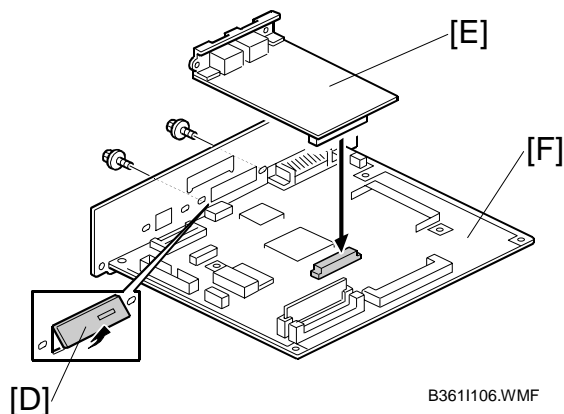

B3611106.WMF

7. Remove the wire handle on the controller panel board and place it on the back side of the left rear cover.
8. Replace the left rear cover.

## 1.7 CHECKING THE CONNECTIONS

1. Plug in the power cord and turn on the main switch.
2. Enter the printer user mode and print the configuration page.  
(User Tools/ Printer Settings/ List Test Print/ Config. Page)  
The same data can also be printed using the printer service mode.  
("Print Summary": SP1-004)

All installed options are listed in the "System Reference" column.

---

## 2. TROUBLESHOOTING

### 2.1 CONTROLLER ERRORS

Refer to section 4.1 of the main unit service manual for descriptions on SC code information because the GW architecture includes controller SC codes in the main unit SC code table.

### 2.2 LEDS AND TEST POINTS

LEDs and test points are not used for this option (except for the NIB  section 4.4).



## 3. SERVICE TABLES

### 3.1 SERVICE PROGRAM MODE

#### CAUTION

Before accessing the service menu, do the following:

Confirm that there is no print data in the printer buffer (the Data In LED must not be lit or blinking).

If there is some data in the buffer, wait until all data has been printed.

#### CAUTION

Never turn off the main power switch when the power LED is lit or flashing. To avoid damaging the hard disk or memory, press the operation power switch to switch the power off, wait for the power LED to go off, and then switch the main power switch off.

Service  
Tables

**NOTE:** The main power LED () lights or flashes while the platen cover or ARDF is open, while the main unit is communicating with a facsimile or the network server, or while the machine is accessing the hard disk or memory for reading or writing data.

#### 3.1.1 ENABLING AND DISABLING SERVICE PROGRAM MODE

##### *Entering the SP mode*



1. Press the Clear Mode key.



2. Use the keypad to enter "107".



3. Hold down Clear/Stop for at least 3 seconds.

4. Enter the Service Mode.

##### **Printer SP**

Press "Printer SP" to enter printer SP mode.

##### **Scanner SP**

Press "Scanner SP" to enter scanner SP mode.

**NOTE:** If you switch the machine off, any jobs stored on the hard disk using the sample print and protected print features will be deleted. Check first if there are any jobs stored with these features (Printer mode: View Sample Print Jobs/View Locked Print Job).

##### *Exiting the Service Mode*

Press "Exit" on the LCD panel to exit from the service mode.

### 3.2 PRINTER SERVICE MODE

#### 3.2.1 SERVICE MODE TABLE

SP No.	Description	Function and Setting
1001	BitSw#1 Set	Adjusts bit switch settings. <b>Note:</b> Currently the bit switches are not being used.
1003	Clear Setting	Not used
1004	Print Summary	Prints the service summary sheet (An error log is printed in addition to the configuration page).
1005	Display Version	Displays the version of the controller firmware.

#### 3.2.2 SP MODES RELATED TO PRINTER CONTROLLER

The following SP modes are located in the copier SP mode. Refer to section 5.1 of the main unit service manual.

SP No.	Description	Function and Setting
5104	A3/DLT Double Count	Specifies whether the counter is doubled for A3/DLT. 0: No, 1: Yes If ① is selected, the total counter and the current user code counter count up twice when A3 or DLT paper is used.
5801	Memory All Clear	Resets data for process control and all software counters, and returns all modes and adjustments to their defaults values. ☛ section 5.1.8 of the main unit manual for details.
5907	Plug & Play	Selects the brand name and the production name for Windows Plug & Play. This information is stored in NVRAM.
7832	Detailed Display of Self-Diagnostics	Displays the controller self-diagnostic result. ☛ section 3.6 of this manual for details.

### 3.3 SCANNER SERVICE MODE

#### 3.3.1 SCANNER PROGRAM MODE TABLE

##### Service Table Key

Notation	What it means
[range / <b>default</b> / step]	Example: [-9 ~ +9 / <b>+3.0</b> / 0.1 mm step]. The setting can be adjusted in the range $\pm 9$ , value reset to +3.0 after an NVRAM reset, and the value can be changed in 0.1 mm steps with each key press.
<i>italics</i>	Comments added for your reference.
*	This value is stored in NVRAM. After a RAM reset, the default value (factory setting) is restored.
DFU	Denotes "Design or Factory Use". Do not change this value.

SP1	Mode Number	Function and [Setting]
1001	1	Model Name Displays the model name.
	2	Scanner Firmware Version Displays the scanner firmware version.
	3	Scanner Firmware Number Displays the firmware's part number.
	4	Detail Model Name Displays the detail model name.
1002	Error Log Display	Displays the error log data.
1003*	FTP Port Number	Changes the FTP port number. <i>After changing this value, do the following:</i> <ol style="list-style-type: none"> <li>1. Run the Registry Editor</li> <li>2. Access /HKEY_LOCAL_MACHINE/SOFTWARE/ Ricoh/NetworkScanner</li> <li>3. Change the value of 'PortNo' to this SP mode's value <u>[0 – 65535 / <b>3670</b> / 1 step]</u></li> </ol>
1004*	Compression Type	Selects the compression type for binary picture processing. <u>[1: MH, 2: MR, 3: <b>MMR</b>]</u>
1005*	Erase Margin	Creates an erase margin for all edges of the scanned image. <i>If the machine has scanned the edge of the original, create a margin.</i> <u>[0 – 5 / <b>0mm</b> / 1mm step]</u>
1006*	Auto Reset Timer	Adjusts the auto reset timer for the scanner function. <i>If this is "0", the auto reset function is disabled.</i> <u>[0, 10 – 99 / <b>60s</b> / 1s step]</u>

<b>SP2</b>	<b>Mode Number</b>		<b>Function and [Setting]</b>
2002	1*	MTF Filter Coefficient (Text / Binary / Main scan)	Selects the MTF filter coefficient in the main scan direction for Text mode. <i>Select a higher number for a stronger filter.</i> <i>If this is "0", the MTF filter is not applied.</i> <u>[0-15 / 7 / 1 step]</u>
	2*	MTF Filter Coefficient (Text / Binary / Sub scan)	As above, for sub scan <u>[0-13 / 6 / 1 step]</u>
	3*	MTF Filter Strength (Text / Binary / Main scan)	Selects the MTF filter strength in the main scan direction for Text mode. <i>Select a higher number for a stronger filter.</i> <u>[0-7 / 5 / 1 step]</u>
	4*	MTF Filter Strength (Text / Binary / Sub scan)	As above, for sub scan <u>[0-7 / 5 / 1 step]</u>
	5*	Smoothing Filter (Text / Binary)	Selects the smoothing pattern for Text mode when using binary picture processing mode. <i>A larger value could cause moiré to appear in the image.</i> <u>[0-7 / 0 / 1 step]</u>
	6*	Scanner Gamma (Text / Binary)	Selects the scanner gamma type for Text mode when using binary picture processing mode. <u>[0-6 / 4 / 1 step]</u>
	7*	Brightness – Notch 7 (Text / Binary)	Adjusts the image density for each image density level for Text mode when using binary picture processing mode. <u>[0-255 / 128 / 1 step]</u>
	8*	Contrast – Notch 7 (Text / Binary)	<u>[0-255 / 128 / 1 step]</u>
	9*	Threshold Level – Notch 7 (Text / Binary)	<u>[0-255 / 160 / 1 step]</u>
	10*	Brightness – Notch 6 (Text / Binary)	<u>[0-255 / 128 / 1 step]</u>
	11*	Contrast – Notch 6 (Text / Binary)	<u>[0-255 / 128 / 1 step]</u>
	12*	Threshold Level – Notch 6 (Text / Binary)	<u>[0-255 / 145 / 1 step]</u>
	13*	Brightness – Notch 5 (Text / Binary)	<u>[0-255 / 128 / 1 step]</u>
	14*	Contrast – Notch 5 (Text / Binary)	<u>[0-255 / 128 / 1 step]</u>
	15*	Threshold Level – Notch 5 (Text / Binary)	<u>[0-255 / 135 / 1 step]</u>
	16*	Brightness – Notch 4 (Text / Binary)	<u>[0-255 / 128 / 1 step]</u>
	17*	Contrast – Notch 4 (Text / Binary)	<u>[0-255 / 128 / 1 step]</u>
	18*	Threshold Level – Notch 4 (Text / Binary)	<u>[0-255 / 128 / 1 step]</u>
	19*	Brightness – Notch 3 (Text / Binary)	<u>[0-255 / 128 / 1 step]</u>

SP2	Mode Number	Function and [Setting]
2002	20*	Contrast – Notch 3 (Text / Binary) Adjusts the image density for each image density level for Text mode when using binary picture processing mode. <u>[0-255 / 128 / 1 step]</u>
	21*	Threshold Level – Notch 3 (Text / Binary) <u>[0-255 / 100 / 1 step]</u>
	22*	Brightness – Notch 2 (Text / Binary) <u>[0-255 / 128 / 1 step]</u>
	23*	Contrast – Notch 2 (Text / Binary) <u>[0-255 / 128 / 1 step]</u>
	24*	Threshold Level – Notch 2 (Text / Binary) <u>[0-255 / 85 / 1 step]</u>
	25*	Brightness – Notch 1 (Text / Binary) <u>[0-255 / 128 / 1 step]</u>
	26*	Contrast – Notch 1 (Text / Binary) <u>[0-255 / 128 / 1 step]</u>
	27*	Threshold Level – Notch 1 (Text / Binary) <u>[0-255 / 70 / 1 step]</u>
	28*	Independent Dot Erase (Text mode) Selects the independent dot erase level. <i>With a larger SP setting, more dots are detected as independent dots and erased.</i> <i>If this is “0”, independent dot erase is disabled.</i> <u>[0-7 / 4 / 1 step]</u>
29*	Unevenness correction (Text mode) Selects whether the unevenness correction is done. <i>This function is like an FCI function. If this is “1”, the edges of characters in scanned images will be smoothed.</i> <u>[0: OFF, 1: ON]</u>	
2003	1*	MTF Filter Coefficient (Text/Photo / Binary / Main scan) Selects the MTF filter coefficient in the main scan direction for Text/Photo mode. <i>Select a higher number for a stronger filter.</i> <i>If this is “0”, the MTF filter is not applied.</i> <u>[0-15 / 4 / 1 step]</u>
	28*	MTF Filter Coefficient (Text/Photo / Binary / Sub scan) As above, for sub scan <u>[0-13 / 4 / 1 step]</u>
	3*	MTF Filter Strength (Text/Photo / Binary / Main scan) Selects the MTF filter strength in the main scan direction for Text/Photo mode. <i>Select a higher number for a stronger filter.</i> <u>[0-7 / 5 / 1 step]</u>
	4*	MTF Filter Strength (Text/Photo / Binary / Sub scan) As above, for sub scan <u>[0-7 / 5 / 1 step]</u>
	5*	Smoothing Filter (Text/Photo / Binary) Selects the smoothing pattern for Text/Photo mode when using binary picture processing mode. <i>A larger value could cause moiré to appear in the image.</i> <u>[0-7 / 0 / 1 step]</u>

SP2	Mode Number	Function and [Setting]
2003	6*	Scanner Gamma (Text/Photo / Binary) Selects the scanner gamma type for Text/Photo mode when using binary picture processing mode. [0-6 / <b>5</b> / 1 step]
	7*	Brightness – Notch 7 (Text/Photo / Binary) Adjusts the image density for each image density level for Text/Photo mode when using binary picture processing mode. [0-255 / <b>15</b> / 1 step]
	8*	Contrast – Notch 7 (Text/Photo / Binary) [0-255 / <b>110</b> / 1 step]
	9*	Threshold Level – Notch 7 (Text/Photo / Binary) <b>This SP is not available.</b> [0-255 / <b>128</b> / 1 step]
	10*	Brightness – Notch 6 (Text/Photo / Binary) [0-255 / <b>25</b> / 1 step]
	11*	Contrast – Notch 6 (Text/Photo / Binary) [0-255 / <b>85</b> / 1 step]
	12*	Threshold Level – Notch 6 (Text/Photo / Binary) <b>This SP is not available.</b> [0-255 / <b>128</b> / 1 step]
	13*	Brightness – Notch 5 (Text/Photo / Binary) [0-255 / <b>27</b> / 1 step]
	14*	Contrast – Notch 5 (Text/Photo / Binary) [0-255 / <b>51</b> / 1 step]
	15*	Threshold Level – Notch 5 (Text/Photo / Binary) <b>This SP is not available.</b> [0-255 / <b>128</b> / 1 step]
	16*	Brightness – Notch 4 (Text/Photo / Binary) [0-255 / <b>70</b> / 1 step]
	17*	Contrast – Notch 4 (Text/Photo / Binary) [0-255 / <b>70</b> / 1 step]
	18*	Threshold Level – Notch 4 (Text/Photo / Binary) <b>This SP is not available.</b> [0-255 / <b>128</b> / 1 step]
	19*	Brightness – Notch 3 (Text/Photo / Binary) [0-255 / <b>69</b> / 1 step]
	20*	Contrast – Notch 3 (Text/Photo / Binary) [0-255 / <b>80</b> / 1 step]
	21*	Threshold Level – Notch 3 (Text/Photo / Binary) <b>This SP is not available.</b> [0-255 / <b>128</b> / 1 step]
	22*	Brightness – Notch 2 (Text/Photo / Binary) [0-255 / <b>100</b> / 1 step]
	23*	Contrast – Notch 2 (Text/Photo / Binary) [0-255 / <b>100</b> / 1 step]
	24*	Threshold Level – Notch 2 (Text/Photo / Binary) <b>This SP is not available.</b> [0-255 / <b>128</b> / 1 step]
	25*	Brightness – Notch 1 (Text/Photo / Binary) [0-255 / <b>128</b> / 1 step]
	26*	Contrast – Notch 1 (Text/Photo / Binary) [0-255 / <b>128</b> / 1 step]
	27*	Threshold Level – Notch 1 (Text/Photo / Binary) <b>This SP is not available.</b> [0-255 / <b>128</b> / 1 step]

SP2	Mode Number	Function and [Setting]
2004	1*	MTF Filter Coefficient (Photo / Binary / Main scan) Selects the MTF filter coefficient in the main scan direction for Photo mode. <i>Select a higher number for a stronger filter.</i> <i>If this is "0", the MTF filter is not applied.</i> [0-15 / 0 / 1 step]
	2*	MTF Filter Coefficient (Photo / Binary / Sub scan) As above, for sub scan [0-13 / 0 / 1 step]
	3*	MTF Filter Strength (Photo / Binary / Main scan) Selects the MTF filter strength in the main scan direction for Photo mode. <i>Select a higher number for a stronger filter.</i> [0-7 / 0 / 1 step]
	4*	MTF Filter Strength (Photo / Binary / Sub scan) As above, for sub scan [0-7 / 0 / 1 step]
	5*	Smoothing Filter (Photo / Binary) Selects the smoothing pattern for Photo mode when using binary picture processing mode. <i>A larger value could cause moiré to appear in the image.</i> [0-7 / 0 / 1 step]
	6*	Scanner Gamma (Photo / Binary) Selects the scanner gamma type for Photo mode when using binary picture processing mode. [0-6 / 6 / 1 step]
	7*	Dither Matrix Filter (Photo / Binary) Selects the dither matrix type for Photo mode when using binary picture processing mode. [1-26 / 4 / 1 step]
	8*	Brightness – Notch 7 (Photo / Binary) Adjusts the image density for each image density level for Photo mode when using binary picture processing mode. [0-255 / 60 / 1 step]
	9*	Contrast – Notch 7 (Photo / Binary) [0-255 / 128 / 1 step]
	10*	Threshold Level – Notch 7 (Photo / Binary) <b>This SP is not available.</b> [0-255 / 128 / 1 step]
	11*	Brightness – Notch 6 (Photo / Binary) [0-255 / 100 / 1 step]
	12*	Contrast – Notch 6 (Photo / Binary) [0-255 / 128 / 1 step]
	13*	Threshold Level – Notch 6 (Photo / Binary) <b>This SP is not available.</b> [0-255 / 128 / 1 step]
	14*	Brightness – Notch 5 (Photo / Binary) [0-255 / 120 / 1 step]
	15*	Contrast – Notch 5 (Photo / Binary) [0-255 / 120 / 1 step]
	16*	Threshold Level – Notch 5 (Photo / Binary) <b>This SP is not available.</b> [0-255 / 128 / 1 step]
	17*	Brightness – Notch 4 (Photo / Binary) [0-255 / 128 / 1 step]

SP2	Mode Number	Function and [Setting]
2004	18*	Contrast – Notch 4 (Photo / Binary) Adjusts the image density for each image density level for Photo mode when using binary picture processing mode. [0-255 / <b>128</b> / 1 step]
	19*	Threshold Level – Notch 4 (Photo / Binary) <b>This SP is not available.</b> [0-255 / <b>128</b> / 1 step]
	20*	Brightness – Notch 3 (Photo / Binary) [0-255 / <b>135</b> / 1 step]
	21*	Contrast – Notch 3 (Photo / Binary) [0-255 / <b>135</b> / 1 step]
	22*	Threshold Level – Notch 3 (Photo / Binary) <b>This SP is not available.</b> [0-255 / <b>128</b> / 1 step]
	23*	Brightness – Notch 2 (Photo / Binary) [0-255 / <b>138</b> / 1 step]
	24*	Contrast – Notch 2 (Photo / Binary) [0-255 / <b>133</b> / 1 step]
	25*	Threshold Level – Notch 2 (Photo / Binary) <b>This SP is not available.</b> [0-255 / <b>128</b> / 1 step]
	26*	Brightness – Notch 1 (Photo / Binary) [0-255 / <b>140</b> / 1 step]
	27*	Contrast – Notch 1 (Photo / Binary) [0-255 / <b>133</b> / 1 step]
28*	Threshold Level – Notch 1 (Photo / Binary) <b>This SP is not available.</b> [0-255 / <b>128</b> / 1 step]	
2005	1*	MTF Filter Coefficient (Grayscale / Main scan) Selects the MTF filter coefficient in the main scan direction when using grayscale processing mode. <i>Select a higher number for a stronger filter.</i> <i>If this is "0", the MTF filter is not applied</i> [0-15 / <b>0</b> / 1 step]
	2*	MTF Filter Coefficient (Grayscale / Sub scan) As above, for sub scan [0-13 / <b>0</b> / 1 step]
	3*	MTF Filter Strength (Grayscale / Main scan) Selects the MTF filter strength in the main scan direction when using grayscale processing mode. <i>Select a higher number for a stronger filter.</i> [0-7 / <b>0</b> / 1 step]
	4*	MTF Filter Strength (Grayscale / Sub scan) As above, for sub scan [0-7 / <b>0</b> / 1 step]
	5*	Smoothing Filter (Grayscale) Selects the smoothing pattern when using grayscale processing mode. <i>A larger value could cause moiré to appear in the image.</i> [0-7 / <b>0</b> / 1 step]
	6*	Scanner Gamma (Grayscale) Selects the scanner gamma type when using grayscale processing mode. [0-6 / <b>3</b> / 1 step]



SP2	Mode Number	Function and [Setting]	
2005	7*	Brightness – Notch 7 (Grayscale) Adjusts the image density for each image density level when using the grayscale processing mode. [0-255 / <b>98</b> / 1 step]	
	8*	Contrast – Notch 7 (Grayscale) [0-255 / <b>98</b> / 1 step]	
	9*	Threshold Level – Notch 7 (Grayscale) <b>This SP is not available.</b> [0-255 / <b>98</b> / 1 step]	
	10*	Brightness – Notch 6 (Grayscale) [0-255 / <b>108</b> / 1 step]	
	11*	Contrast – Notch 6 (Grayscale) [0-255 / <b>108</b> / 1 step]	
	12*	Threshold Level – Notch 6 (Grayscale) <b>This SP is not available.</b> [0-255 / <b>108</b> / 1 step]	
	13*	Brightness – Notch 5 (Grayscale) [0-255 / <b>118</b> / 1 step]	
	14*	Contrast – Notch 5 (Grayscale) [0-255 / <b>118</b> / 1 step]	
	15*	Threshold Level – Notch 5 (Grayscale) <b>This SP is not available.</b> [0-255 / <b>118</b> / 1 step]	
	16*	Brightness – Notch 4 (Grayscale) [0-255 / <b>128</b> / 1 step]	
	17*	Contrast – Notch 4 (Grayscale) [0-255 / <b>128</b> / 1 step]	
	18*	Threshold Level – Notch 4 (Grayscale) <b>This SP is not available.</b> [0-255 / <b>128</b> / 1 step]	
	19*	Brightness – Notch 3 (Grayscale) [0-255 / <b>138</b> / 1 step]	
	20*	Contrast – Notch 3 (Grayscale) [0-255 / <b>138</b> / 1 step]	
	21*	Threshold Level – Notch 3 (Grayscale) <b>This SP is not available.</b> [0-255 / <b>138</b> / 1 step]	
	22*	Brightness – Notch 2 (Grayscale) [0-255 / <b>148</b> / 1 step]	
	23*	Contrast – Notch 2 (Grayscale) [0-255 / <b>148</b> / 1 step]	
	24*	Threshold Level – Notch 2 (Grayscale) <b>This SP is not available.</b> [0-255 / <b>148</b> / 1 step]	
	25*	Brightness – Notch 1 (Grayscale) [0-255 / <b>158</b> / 1 step]	
	26*	Contrast – Notch 1 (Grayscale) [0-255 / <b>158</b> / 1 step]	
	27*	Threshold Level – Notch 1 (Grayscale) <b>This SP is not available.</b> [0-255 / <b>158</b> / 1 step]	
	2006	1*	Compression Ratio (Normal image) Selects the compression ratio for grayscale processing mode. <i>For a lower compression rate, input a smaller value.</i> [5-95 / <b>50</b> / 1 step]

SP2	Mode Number		Function and [Setting]
2006	2*	Compression Ratio (High Quality image)	[5-95 / <b>60</b> / 1 step]
	3*	Compression Ratio (Low Quality image)	[5-95 / <b>40</b> / 1 step]

SP8	Mode Number		Function and [Setting]
8001*		Delivery Server IP Address	Sets the IP address for the delivery server. <b>[000.000.000.000]</b>
8002	1*	Delivery Re-try (Interval)	Sets the delivery re-try interval. <b>[60-999 / 300s / 1s step]</b>
	2*	Delivery Re-try (Number of re-try)	Sets the number of delivery re-tries. <i>If this is "0", the machine will not re-try to send an image to the delivery server.</i> <b>[0-99 / 3 times / 1 time step]</b>
8003*		ECabinet IP Address	Sets the IP address for the eCabinet. <b>[000.000.000.000]</b>
8004*		Network Error Display Time	Selects the length of time that the network error message for the scanner utilities is displayed. <i>If this is "0", the error message is displayed until the error is solved.</i> <b>[0-999 / 300 s / 1 s step]</b>

SP9	Mode Number		Function and [Setting]
9001	1	Sysop	Bit switches for debugging. <b>DFU</b>
	2	Dapp	
	3	Rapp	
	4	Ui	
	5	Nas	
	6	Miw	
	7	Djm	
	8	Hpim	
	9	mib	

## 3.4 FIRMWARE UPDATE PROCEDURE

Firmware updating procedure is described in section 5.2 of the main unit service manual.

## 3.5 POWER-ON SELF TEST

The controller tests the following devices at power-on. If an error is detected, an error code is stored in the controller board.

- CPU, ASIC and clock
  - Flash ROM
  - Resident and optional SDRAM
  - Parallel interface
  - NIB
  - IEEE1394 interface (if installed)
  - NVRAM
  - HDD
- 
- Refer to section 4.1.2 of the main unit service manual for how to check the error codes (SP 7-832).

## 3.6 SELF DIAGNOSTIC TEST

In addition to the power-on self test, you can set the machine in a more detailed diagnostic mode to test other components and conditions. It requires a loop-back connector (P/N: G0219350).

1. Turn off the machine and attach the loop-back connector to the parallel interface.
2. Turn on the machine while pressing the “On Line” key and “# Enter” key together.
3. The machine prints the diagnostic report automatically.
  - Refer to section 4.1.2 of the main unit service manual for how to check the error codes (SP 7-832).

### 3.7 USER PROGRAM MODE

#### 3.7.1 PRINTER USER PROGRAM MODE

Press the "Printer" key on the operation panel to enter the printer mode.  
Press the "User Tools/Counter ", then select "Printer Settings" to change printer settings.

#### User Mode Tree

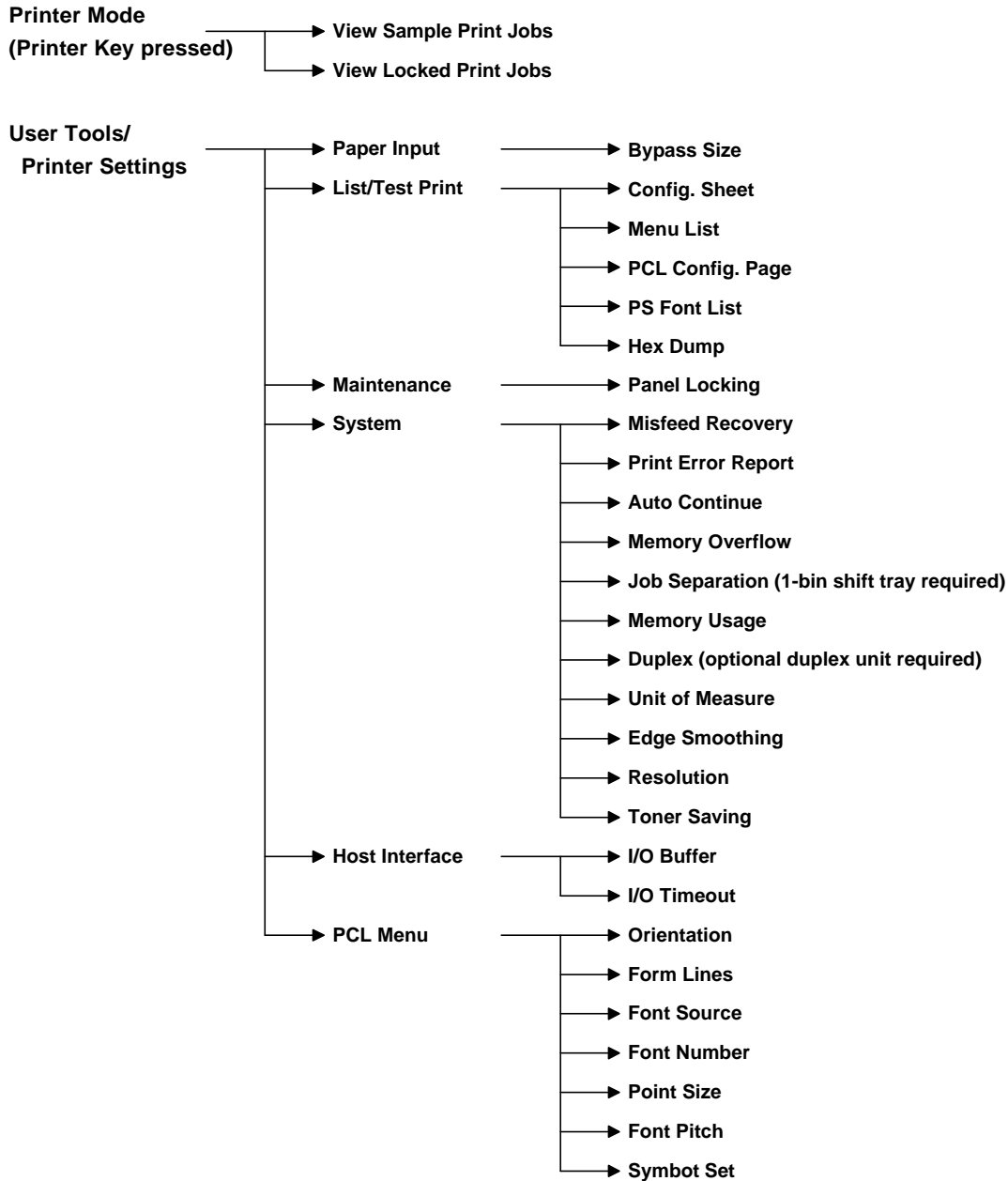

### 3.7.2 SCANNER USER PROGRAM MODE

Press the “User Tools/Counter ”, then select “Scanner Settings” to change scanner settings.

#### User Mode Tree

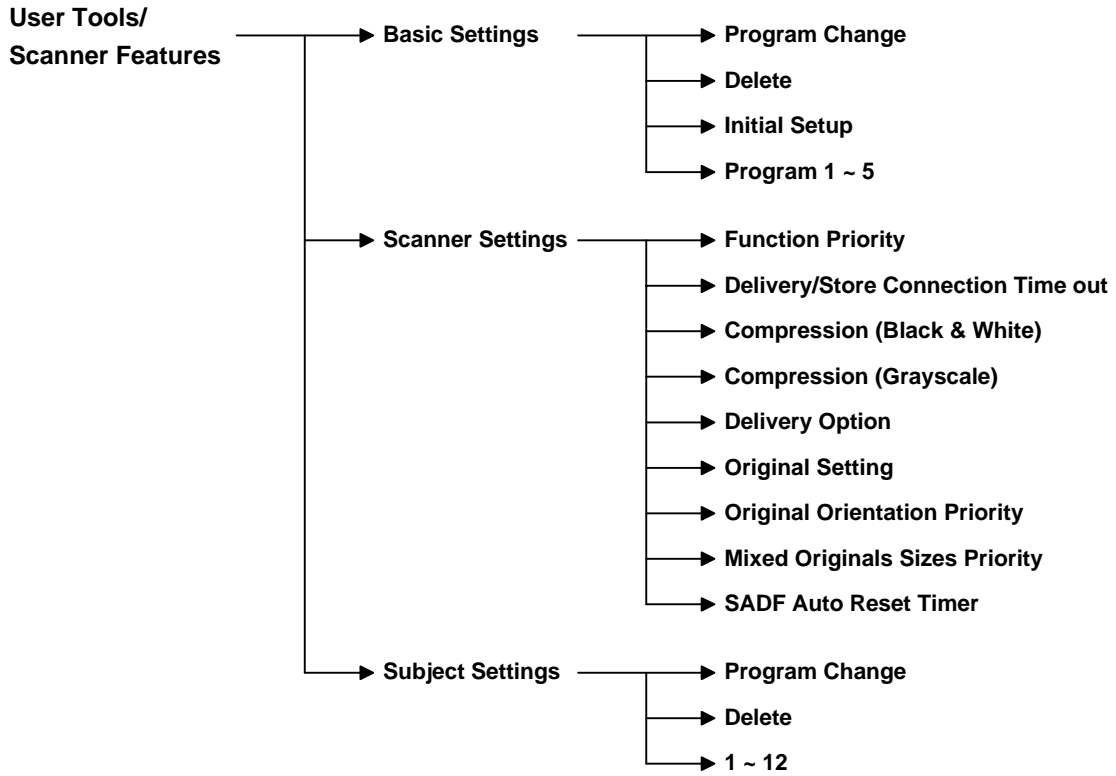

## 4. DETAILED SECTION DESCRIPTIONS

### 4.1 OVERVIEW

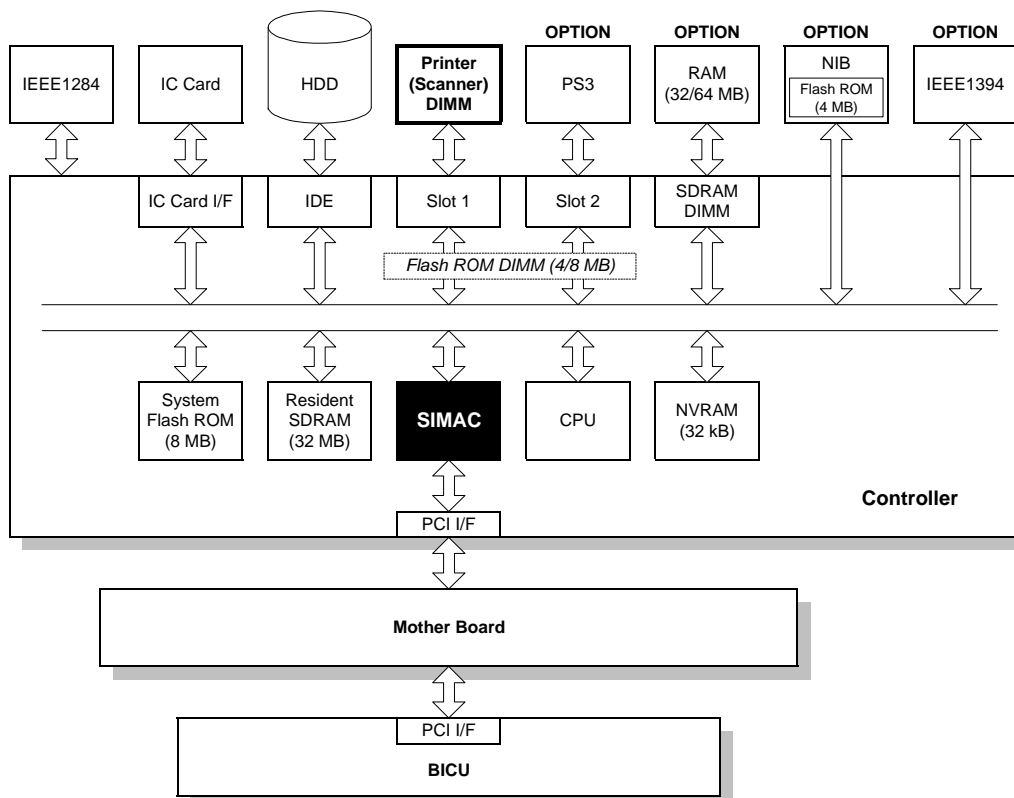

B362D501.WMF

This machine uses the GW architecture. To enable the printer features, just install the printer option ROM DIMM on the controller.

Main components:

- CPU: QED RM5231
- SIMAC: GW architecture ASIC. It controls all the functions of the controller board.
- Flash ROM: 8MB Flash ROM for the system program
- SDRAM (resident): 32 MB SDRAM, expandable with 32 MB or 64 MB optional SDRAM.
- NVRAM: Stores the controller settings
- HDD: Used to store additional soft fonts. Also used for collation, locked print, sample print and form overlay
- IEEE 1284 interface

Optional components:

- PostScript3 DIMM
- Memory DIMM
- NIB
- IEEE1394 interface

## **4.2 CONTROLLER FUNCTIONS**

### **4.2.1 SAMPLE PRINT**

This feature was formerly known as “Proof Print”. This function gives users a chance to check the print results before starting a multiple-set print run.

- The size of the hard disk partition for the sample print feature is 5 GB. This partition is also used by the collation and locked print features.
- The partition can hold up to 30 files, including files stored using locked print.
- The maximum number of pages is 2,000, including jobs using locked print and collation.

### **4.2.2 LOCKED PRINT**

Using this feature, the print job is stored in the machine but will not be printed until the user inputs an ID at the machine’s operation panel. This ID must match the ID that was input with the printer driver.

- Stored data is automatically deleted after it is printed.
- Stored data can be manually deleted at the operation panel.
- The hard disk can hold up to 30 files, including files stored using sample print.
- The maximum number of pages is 2,000, including jobs using sample print and collation.
- Locked print uses the same hard disk partition as sample print and collation, which is 5 GB.

### 4.2.3 PAPER SOURCE SELECTION

#### **Tray Priority (Auto Tray Select)**

The Tray Priority setting determines the start of the tray search when the user selects “Auto Tray Select” with the driver. The machine searches for a paper tray with the specified paper size and type.

When no tray contains paper that matches the paper size and type specified by the driver, the controller stops printing until the user loads the correct paper.

The Tray Priority setting can be specified using the Paper Size Setting in the user tools. (User Tools/ System Settings/ Paper Size Settings)

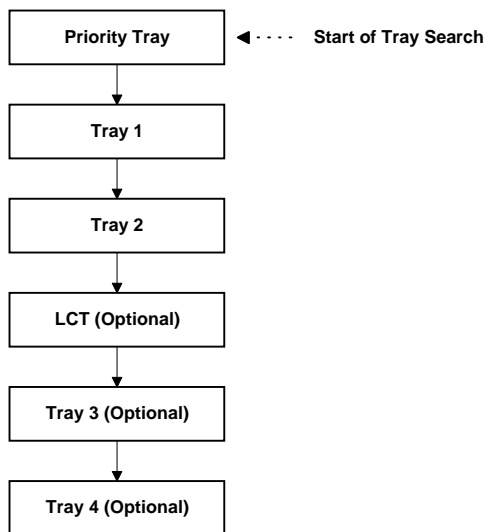

B362D502.WMF

**NOTE:** The by-pass tray is not part of the tray search.

#### **Tray Lock**

If Tray Lock is enabled for a tray, the controller skips the “locked” tray in the tray search process.

The Tray Lock setting can be specified by selecting “No” for the “Apply Auto Paper Select” setting in the Paper Size Setting screen in the user tools. (User Tools/ System Settings/ Paper Size Settings)

**NOTE:** The by-pass feeder cannot be locked.

#### **Manual Tray Select**

If the selected tray does not have the paper size and type specified by the driver, the controller stops printing until the user loads the correct paper.

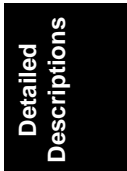



### 4.2.4 AUTO CONTINUE

When this function is enabled, the machine stops printing and cancels the print job if there is no paper tray which matches the paper size and paper type specified by the driver.

If Auto Continue is enabled, the machine waits for a specified period (0, 1, 5, 10, 15 minutes) for the correct size paper to be set in the tray, then cancels the print job if the interval expires.

- The interval can set with the Printer Settings in the user tools.  
(User Tools/ Printer Settings/ System/ Auto Continue)

If Auto Continue is disabled, the machine will not print the job, but will not cancel it, so the job stays in the print queue.

**If no paper tray matches the paper size and paper type specified by the driver:**

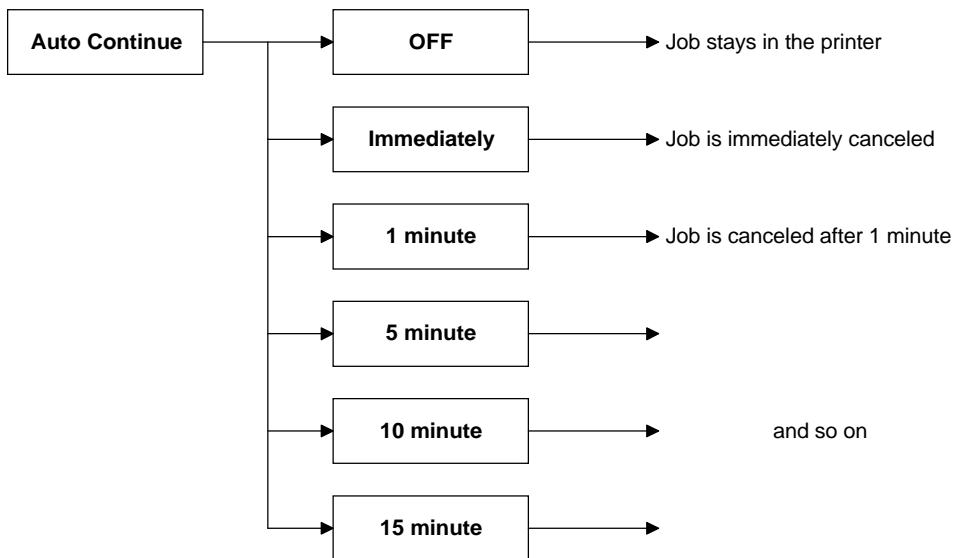

B362D512.WMF

**NOTE:** The default setting for Auto Continue is “Off.”

## 4.2.5 PAPER OUTPUT TRAY

The default paper output tray for each application (copy/fax/printer) can be selected using the System Settings menu in the user tools. (User Tools/ System Settings/ General Features)

If a print job does not specify an output tray or if the driver specifies the default tray, the default paper output tray is used.

### **Output Tray Selected**

- If an output tray is specified by the driver, it overrides the default tray setting in the user tools.
- If the machine cannot print to the selected output tray, it prints to the default paper output tray.
- If the mailbox unit is installed, paper larger than B4 cannot be printed to the standard (internal) tray.
- If paper overflow is detected at the selected output tray, the controller stops printing until the overflow detector goes off.

### **Sequential Stacking**

When the nine-tray mailbox is selected as the output tray and "Printer Default" is specified as the output tray in the driver, the machine automatically sends the output to the top tray (1st tray). When that tray fills up, the machine sends the output to the next tray.

This feature is called "Sequential Stacking."

- If a tray becomes full and paper is detected in the next tray, the machine displays an error and stops printing. When paper in the next tray is removed, the machine automatically resumes printing to the next tray.
- If all trays become full (overflow detected in all trays), the machine displays an error and stops printing. This time, all paper in all trays must be removed.

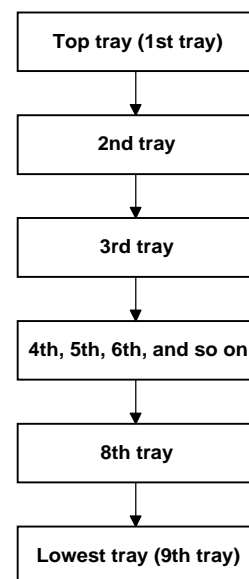

B362D509.WMF

Detailed  
Descriptions

## 4.2.6 DUPLEX PRINTING

Duplex printing is available with all output bin options but not all paper sizes. If a job specifies duplex printing but the paper size to be used cannot be used by the duplex unit, the job will be printed single-sided.

- When the by-pass feeder is selected as the paper source, duplex printing is automatically disabled.

### 4.2.7 STAPLING

Stapling is available when the two-tray (2250-sheet) finisher or 1000-sheet finisher is installed.

The finishers have the following stapling positions.

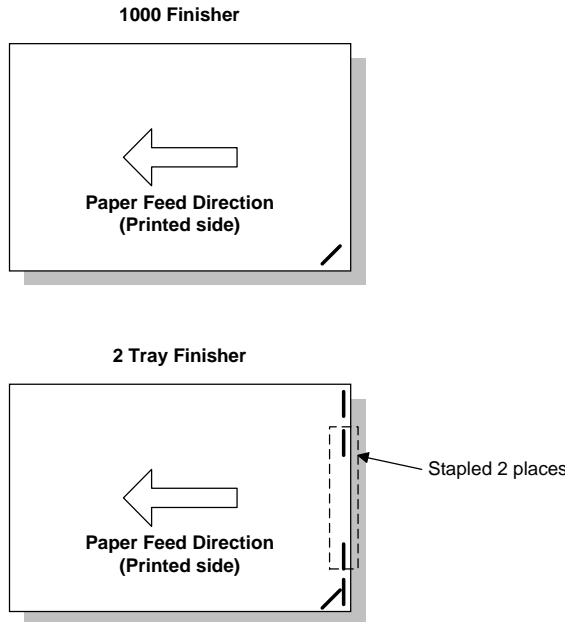

B362D510.WMF

- Depending on the paper orientation, the image may have to be rotated. The image rotation is done by the controller.
- There is a limit for the number of sheets which can be stapled. If a job has more than this number, it will not be stapled.

### 4.2.8 PUNCHING

Punching is available only when the punch kit is installed with the two-tray finisher. The number of holes (2, 3, or 4 holes) depends on the type of punch kit.

- There is only one punch position available, so the relationship between the punching position and the printed image depends on the paper feeding orientation and image rotation.

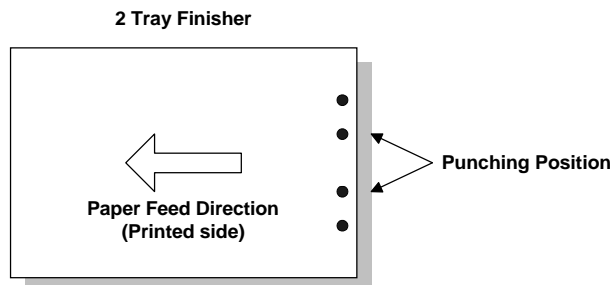

B362D511.WMF

## 4.3 SCANNER FUNCTIONS

### 4.3.1 IMAGE PROCESSING FOR SCANNER MODE

The image processing for scanner mode is done in the IPU chip on the BICU board. The IPU chip chooses the most suitable image processing methods (gamma tables, dither patterns, etc) depending on the settings made in the driver.

The image compression method can be selected with SP mode (MR/MH/MMR for binary picture processing, JPEG for grayscale processing).

Whether the user selects the image mode using the driver (TWAIN mode) or from the operation panel (Delivery mode), the IPU chip does the image processing using the appropriate image processing methods mentioned above.

#### Image Data Path

##### 1. Image Store/Image Delivery Mode

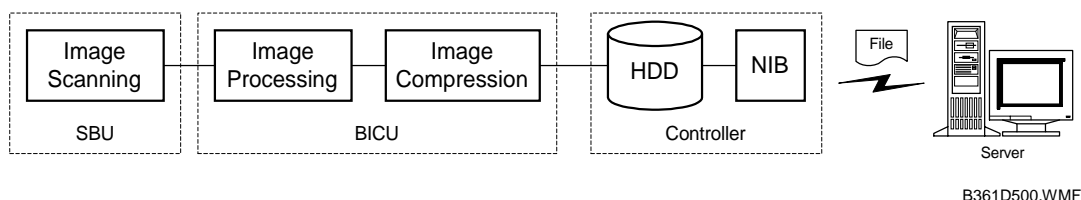

Detailed Descriptions

The user can select the following modes from the LCD.

- 1) Delivery only
- 2) Store only
- 3) Store and delivery

After image processing and image compression, all image data for the job are stored in the printer controller HDD using TIFF file format (binary picture processing) or JPEG file format (grayscale processing). The type of TIFF format used depends on the user's scanner settings.

When delivery mode is selected, the controller creates a file which contains the destination and page information, then the controller sends the file to a server.

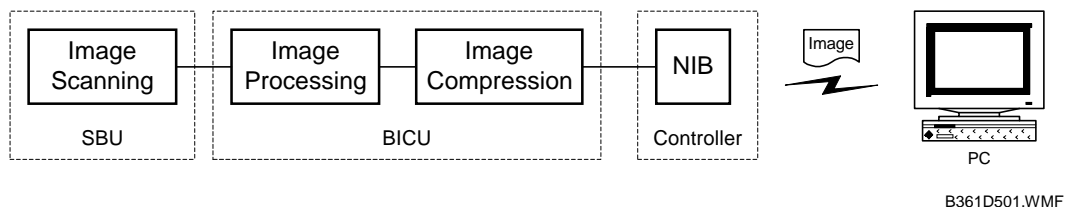

##### 2. Twain Mode

After image processing and image compression, the data (TIFF or JPEG) is sent to the scanner Twain driver directory on the computer.

## 4.4 NIB

### 4.4.1 BLOCK DIAGRAM

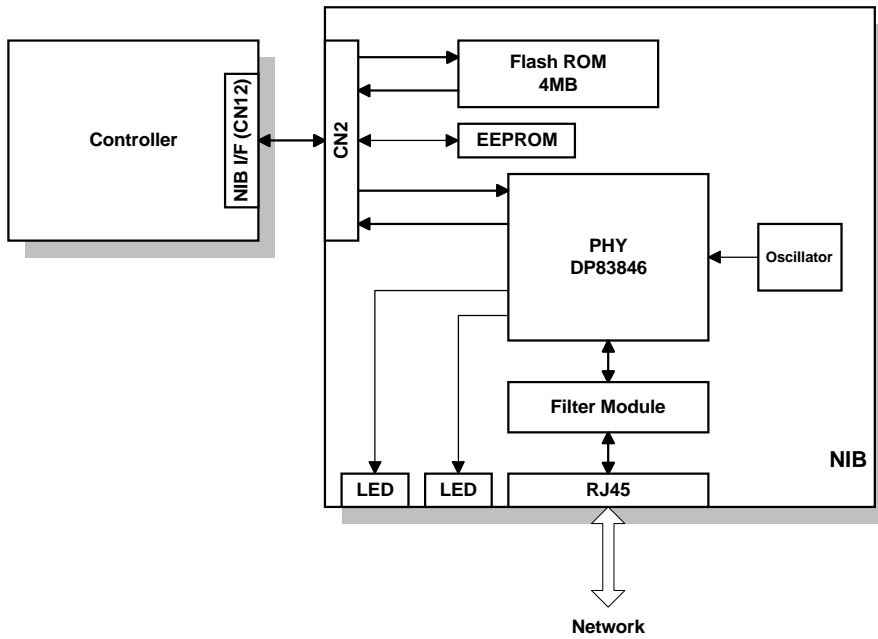

B362D503.WMF

- The Flash ROM contains the NIB firmware. The firmware can be upgraded using an IC card connected to the controller board.

### 4.4.2 LED INDICATORS

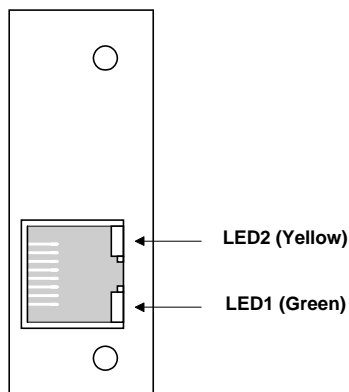

B362D508.WMF

Description	On	Off
LED1 (Green): Link status	Link success	Link failure
LED2 (Yellow): Data rate	100 Mbps	10 Mbps

## 4.5 IEEE1394 INTERFACE

### 4.5.1 SPECIFICATIONS

#### *Hardware Specification*

Interface: IEEE1394 (6 pins)  
 (no power supply, cable power repeated, IEEE1394a-2000 compliant)  
 Ports: 2 ports  
 Data rates: 400Mbps/200Mbps/100Mbps

#### *System Requirements*

PC: Windows PC with IEEE1394 port  
 OS: Microsoft Windows 2000 upgraded with service pack 1  
 Cable length: 4.5m (15ft)

### 4.5.2 IEEE1394

IEEE1394, also known as FireWire (a name patented by Apple), is an easy-to-use peer-to-peer networking technology allowing speeds of up to 400 Mbps.

The current standard contains the following features, which are supported in most devices:

- Hot swapping (cables can be connected and disconnected while the computer and other devices are switched on)
- Peer-to-peer networking (no hub required)
- No terminator or device ID is required, unlike SCSI
- Automatic configuration of devices upon start-up, or “plug and play.”
- Real-time data transfer at 100, 200, and 400 Mbps
- Common connectors for different devices

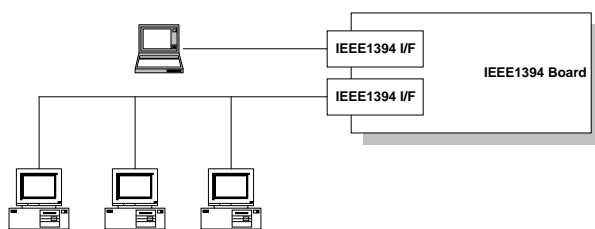

B362D506.WMF

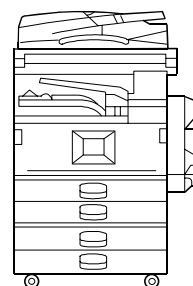

B362V503.WMF

The cable length is limited to 4.5 m (15ft).

However, up to 16 cables and 63 devices can be connected to an IEEE1394 network.

IEEE1394 cables can be either 4-pin (data only) or 6-pin (data and power). IEEE1394 allows either 6-pin or 4-pin connectors. However, this machine only uses the 6-pin connectors. The machine has two 6-pin ports.

### 4.5.3 BLOCK DIAGRAM

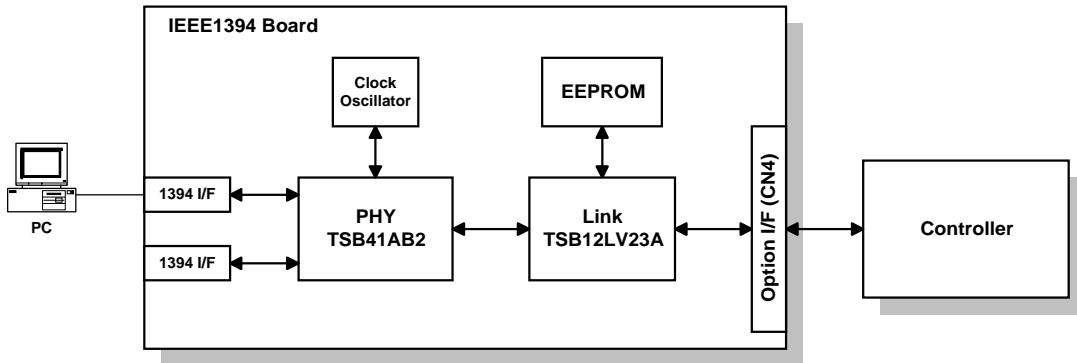

B362D505.WMF

- PHY: Physical layer control device
- Link: Link layer control device
- EEPROM: 256-byte ROM

### 4.5.4 PIN ASSIGNMENT

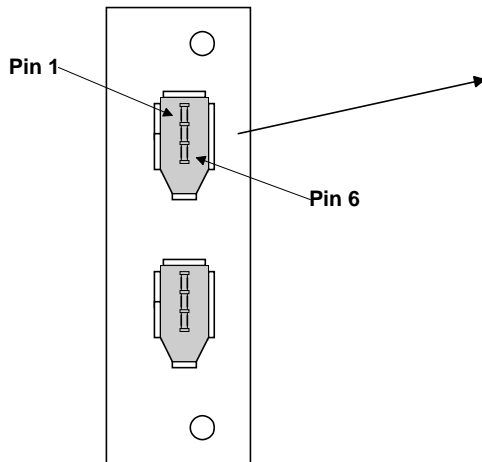

Pin assignment	
Pin 1	Pin 4
Pin 2	Pin 3
Pin 5	Pin 6

B362D507.WMF

Pin No.	Signal Description
1	Cable Power
2	GND
3	Receive strobe
4	Transmit data
5	Receive data
6	Transmit strobe

### 4.5.5 REMARKS ABOUT THIS INTERFACE KIT

Note the following points about this unit.

- The machine does not print reports specifically for IEEE1394. Just print the Configuration Page at installation to check that the machine recognizes the card.
- There is no spooler or print queue. If a computer tries to print over the IEEE1394 while the printer is busy, the IEEE1394 interface card inside the printer will return a busy signal.
- After starting a job using IEEE1394, do not switch the printer off until the job has been completed. Even though the printer may appear to be dead, it may be in the middle of an IEEE1394 protocol exchange with the computer.
- When using IEEE1394, it is not possible to check the printer status from the computer with a utility such as Printer Manager for Client.

### 4.5.6 TROUBLESHOOTING NOTES

If there are problems printing using the IEEE1394 interface, check the following.

- Is the computer using Windows 2000 with service pack 1?
- Has the interface card been replaced recently? Each card has an individual address, similar to the MAC address in an Ethernet card. If the card was changed, the driver cannot find the old card. The new card is another device and a new printer appears in Windows Control panel, and this must be configured in the same way as the printer that was replaced (the old printer icon in Windows Control Panel should be deleted) has to be reconfigured.
- Is there a loop somewhere in the network? An IEEE1394 network must be a chain or a branched chain. There can be no loops.
- Try to find out where in the chain the problem is occurring. Test the machine one-to-one with the computer to determine if the printer is defective (when the printer's interface cable is plugged in, the computer should see 'Printer Ready'; when the cable is disconnected, the computer should see 'Offline').



---

# SPECIFICATIONS

## 1. GENERAL SPECIFICATIONS

### 1.1 PRINTER

Printing Speed:	Maximum 45 ppm (A4/LT LEF): B004/B007 model Maximum 35 ppm (A4/LT LEF): B003/B006 model
Printer Languages:	PCL6/PCL5e PostScript 3 (option) RPCS (Refined Printing Command Stream) - an original Ricoh PDL
Resolution:	600 dpi (PCL 6/PCL5e/PS3/RPCS) 300 dpi (PCL5e/PS3)
Resident Fonts:	PCL: 35 Intellifonts 10 True Type fonts PS3: 136 fonts (24 Type 2 fonts, 112 Type 14 fonts)
Host Interfaces:	Bi-directional IEEE1284 parallel x 1 (standard) Ethernet (100 Base-TX/10 Base-T) (option) IEEE1394 (option)
Network Protocols:	TCP/IP, IPX/SPX, NetBEUI, Apple Talk
Memory:	Maximum 96 MB (Standard 32 MB + 32 MB/64MB optional DIMM)

**Supported Paper Sizes**

Paper	Size (W x L)	Paper Trays		By-pass Tray	LCT	Duplex
		Main Unit/Option				
		US	Eur/Asia			
A3	297 x 420 mm	Y <sup>#</sup> /Y <sup>#</sup>	Y/Y	Y <sup>#</sup>	N	Y
B4	257 x 364 mm	Y <sup>#</sup> /Y <sup>#</sup>	Y <sup>#</sup> /Y <sup>#</sup>	Y <sup>#</sup>	N	Y
A4 SEF	210 x 297 mm	Y/Y	Y/Y	Y <sup>#</sup>	N	Y
A4 LEF	297 x 210 mm	Y/Y	Y/Y	Y <sup>#</sup>	Y	Y
B5 SEF	182 x 257 mm	Y <sup>#</sup> /Y <sup>#</sup>	Y <sup>#</sup> /Y <sup>#</sup>	Y <sup>#</sup>	N	Y
B5 LEF	257 x 182 mm	Y <sup>#</sup> /Y <sup>#</sup>	Y <sup>#</sup> /Y <sup>#</sup>	Y <sup>#</sup>	N	Y
A5 SEF	148 x 210 mm	Y <sup>#</sup> /Y <sup>#</sup>	Y/Y	Y <sup>#</sup>	N	Y
A5 LEF	210 x 148 mm	N	N	Y <sup>#</sup>	N	N
B6 SEF	128 x 182 mm	N	N	Y <sup>C</sup>	N	N
B6 LEF	182 x 128 mm	N	N	N	N	N
A6 SEF	105 x 148 mm	N	N	Y <sup>C</sup>	N	N
Ledger	11 x 17"	Y/Y	Y <sup>#</sup> /Y <sup>#</sup>	Y <sup>#</sup>	N	Y
Legal	8.5 x 14"	Y/Y	Y <sup>#</sup> /Y <sup>#</sup>	Y <sup>#</sup>	N	Y
Letter SEF	8.5 x 11"	Y/Y	Y/Y	Y <sup>#</sup>	N	Y
Letter LEF	11 x 8.5"	Y/Y	Y/Y	Y <sup>#</sup>	Y	Y
Half Letter SEF	5.5 x 8.5"	Y/Y	Y <sup>#</sup> /Y <sup>#</sup>	Y <sup>#</sup>	N	Y
Half Letter LEF	8.5 x 5.5"	N	N	N	N	N
Executive SEF	7.25 x 10.5"	Y <sup>#</sup> /Y <sup>#</sup>	Y <sup>#</sup> /Y <sup>#</sup>	Y <sup>#</sup>	N	Y
Executive LEF	10.5 x 7.25"	N	N	Y <sup>#</sup>	N	Y
F	8 x 13"	Y <sup>#</sup> /Y <sup>#</sup>	Y <sup>#</sup> /Y <sup>#</sup>	Y <sup>#</sup>	N	Y
Foolscap	8.5 x 13"	Y <sup>#</sup> /Y <sup>#</sup>	Y <sup>#</sup> /Y <sup>#</sup>	Y <sup>#</sup>	N	Y
Folio	8.25 x 13"	Y <sup>#</sup> /Y <sup>#</sup>	Y <sup>#</sup> /Y <sup>#</sup>	Y <sup>#</sup>	N	Y
Com10 Env.	4.125 x 9.5"	N	N	N	N	N
Monarch Env.	3.875 x 7.5"	N	N	N	N	N
C6 Env.	114 x 162 mm	N	N	N	N	N
C5 Env.	162 x 229 mm	N	N	N	N	N
DL Env.	110 x 220 mm	N	N	N	N	N
8K	267 x 390 mm	Y <sup>#</sup> /Y <sup>#</sup>	Y <sup>#</sup> /Y <sup>#</sup>	Y <sup>#</sup>	N	Y
16K SEF	195 x 267 mm	Y <sup>#</sup> /Y <sup>#</sup>	Y <sup>#</sup> /Y <sup>#</sup>	Y <sup>#</sup>	N	Y
16K LEF	267 x 195 mm	Y <sup>#</sup> /Y <sup>#</sup>	Y <sup>#</sup> /Y <sup>#</sup>	Y <sup>#</sup>	N	Y
Custom	Minimum: 100 x 297 mm Maximum: 148 x 600 mm	N	N	Y <sup>C</sup>	N	N

**Remarks:**

Y	Supported. The paper size sensor detects the paper size.
Y <sup>#</sup>	Supported. The user has to select the correct paper size for the tray.
Y <sup>C</sup>	Supported. The user has to enter the width and length of the paper.
N	Not supported.

## 1.2 SCANNER

Standard Scanner Resolution:	Main scan/Sub scan 600 dpi
Available scanning Resolution Range:	Twain Mode: Book Mode (Main scan/Sub scan) 100 ~ 2400 dpi ADF Mode (Main scan/Sub scan) 100 ~ 1200 dpi  Delivery Mode: Book and ADF Mode (Main scan/Sub scan) 100 ~ 600 dpi
Grayscales:	8 bits/pixel
Scanning Throughput:	25 spm for TWAIN 53 spm for Delivery mode (A4L, ADF mode)
Interface:	Ethernet (100 Base-TX/10 Base-T for TCP/IP)
Compression Method:	MH, MR, MMR (Binary Picture Processing) JPEG (Grayscale Processing)
Video Memory Capacity:	8.3 MB (Twain) 24.9 MB (Delivery mode)
Image Storage Capacity:	Number of originals per file: Maximum 160 pages Maximum of files: 3000 files

## 2. SOFTWARE ACCESSORIES

### 2.1 PRINTER

The printer drivers and utility software are provided on one CD-ROM. An auto-run installer allows you to select which components to install.

#### **PRINTER DRIVERS**

Printer Language	Windows 95/98/ME	Windows NT4.0	Windows 2000	Macintosh
PCL 6	Yes	Yes	Yes	No
PCL 5e	Yes	Yes	Yes	No
PS3	Yes	Yes	Yes	Yes
RPCS	Yes	Yes	Yes	No

- NOTE:** 1) The printer drivers for Windows NT 4.0 are only for the Intel x86 platform. There is no Windows NT 4.0 printer driver for the PowerPC, Alpha, or MIPS platforms.
- 2) The PS3 drivers are all genuine AdobePS drivers, except for Windows 2000, which uses Microsoft PS. A PPD file for each operating system is provided with the driver.

#### **UTILITY SOFTWARE**

Software	Description
Agfa Font Manager (Win 95/98/ME, NT4, 2000)	A font management utility with screen fonts for the printer.
SmartNetMonitor for Admin (Win 95/98/ME, NT4, 2000)	A printer management utility for network administrators. NIB setup utilities are also available.
SmartNetMonitor for Client (Win 95/98/ME, NT4, 2000)	A printer management utility for client users. Peer-to-peer printing utility and parallel/recovery printing functions are included.
1394 Utility (Win 2000)	A utility for removal IEEE 1394 printers.
DeskTopBinder V2 Lite (Win 95/98/ME, NT4, 2000)	A utility for document management
LAN-Fax M1 (Win 95/98/ME, NT4, 2000)	PC LAN FAX driver
Address Book (Win 95/98/ME, NT4, 2000)	A utility for PC LAN FAX.
Printer Utility for Mac	This software provides several convenient functions for printing from Macintosh clients.

## **2.2 SCANNER**

The scanner driver and utility software are provided on one CD-ROM.

### ***SCANNER DRIVER***

- Network Twain Driver for Win95/98/ME/NT3.51/NT4.0/2000

### ***SCANNER UTILITIES***

- Scan Router V2 Lite (Cherry-Lite) for Win95/98/ME/NT4.0/2000
- Desk Top Binder V2 Lite (Plumeria-Lite) for Win95/98/ME/NT4.0/2000

### 3. MACHINE CONFIGURATION

#### 3.1 SYSTEM COMPONENTS

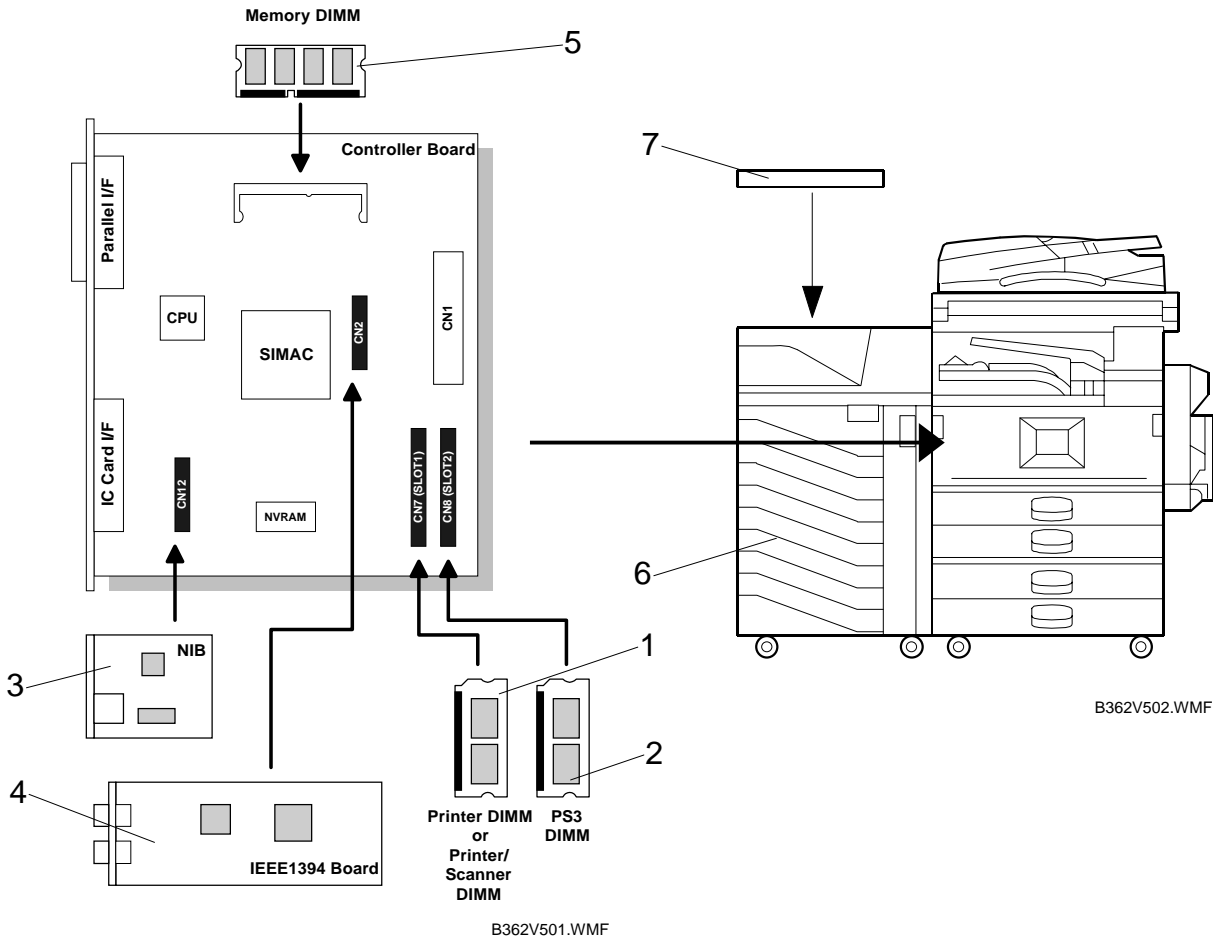

Item	Machine Code	No.	Remarks
Printer Module (ROM DIMM)	B362	1	
Printer/Scanner Module (ROM DIMM)	B361	1	
<b>Option</b>			
Mailbox	G909	6	Used in common with the NAD and Adonis-C1 (USA only).
Mailbox Bridge Unit	G912	7	
<b>Internal Option</b>			
NIB	G574	3	
PostScript3	G577	2	
Memory 64 MB	G579		Used in common with the model J and K-P1.
IEEE1394	G590	4	